

# Compensation Objectives and CPC – Based Generation of Reference Signals for Shunt Switching Compensator Control

Leszek S. Czarnecki and Samuel E. Pearce

**Abstract** — Compensation objectives in three-phase asymmetrical systems with nonsinusoidal voltages and currents, from the perspective of the loading and/or supply quality improvement, are discussed and classified in the paper. It also presents fundamentals of generation of the reference signal for shunt switching compensator (SSC) control with the Currents' Physical Components (CPC) power theory. The paper shows that the CPC enables us for fitting the control algorithms to various objectives of compensation and to the load properties. This is because the CPC power theory, being founded on power phenomena in electrical systems, provides clear insight into power properties of electrical loads.

In spite of the fact that the CPC power theory represents a frequency-domain approach to the identification of the power properties, the paper shows that the CPC based algorithms are not very computationally demanding and enable us a quasi instantaneous control of switching compensators.

*Keywords*-Active filters, conditioners; harmonic distortion; unbalanced systems, .

## I. INTRODUCTION

Compensation objectives and generation of control signals for shunt switching compensators, (SSCs) control, know as “active power filters”, “active harmonic filters” or “power conditioners” are the subject of this paper. Although this is not the main issue, a reader should observe, that the name of these devices is not well established. Moreover, the main features of such devices are not characterized by these names. These are not active, but passive devices in the sense, that they are not sources of energy, but dissipate it. Their operation is not based on filtering, but on *compensation* of the undesirable component of the supply current by a current shaped by a fast-switched PWM inverter and injected into the supply system. These are *compensators*, not filters. They can reduce not only harmonics, but also the reactive current and/or to balance the load. Thus, the adjective “harmonics” does not describe them well. Because *switching* is their main feature that distinguishes such devices from reactive LC compensators, they could be called *switching compensator*, although, perhaps a better name might be coined. Anyway, a discussion on selection of a proper name for these devices is desirable.

Although such applications were reported [6, 10, 11], the Currents' Physical Components (CPC) power theory is not usually considered as a theoretical tool for generating reference signals for control of switching compensators. This is because, the CPC, being based on the frequency-domain approach, is regarded to be less suitable for such purpose than, for example, the Instantaneous Reactive Power (IRP) p-q Theory, being based on the time-domain approach. In fact, the CPC can be a convenient tool for generating reference signals for compensator control, capable of providing such signals almost instantaneously.

Compensators in distribution systems where voltages and currents can be distorted, and/or asymmetrical, are installed not only for the power factor improvement, but also to improve the supply and/or the loading quality. Therefore, objectives of their installation are much more sophisticated as compared to those in sinusoidal, symmetrical systems and are closely related to the supply and/or loading quality improvement. Unfortunately, a reader could observe, however, that very often these objectives in papers on compensation are not defined or are defined vaguely. Therefore, various objectives of compensation, with respect to the supply and loading quality improvement and their classification are discussed in the paper as well.

## II. SUPPLY QUALITY AND LOADING QUALITY

The cost of energy delivery to a load is the lowest when the load is purely resistive, balanced and its parameters do not change in time. This is an ideal situation for energy delivery and the load can be regarded as an *ideal load*. The load reactance, imbalance, generation of current harmonics, noise or transients and time variability of the load parameters contribute to an increase in the cost of energy delivery. Any such deviation of the load features from the ideal load can be referred to as degradation in the *loading quality*.

On the other hand, energy utilization by customer loads is the most effective, meaning at the lowest cost, when they are supplied with a sinusoidal and symmetrical voltage with fixed rms value, without any sags, swells, transients or noise. Such a supply can be regarded as an *ideal supply*. The load performance and consequently, the effectiveness of energy utilization by the load degrades with the supply voltage harmonics and asymmetry, fluctuations of its rms value, transients, sags or high frequency noise. All these features contribute to an increase in the cost of energy utilization by the customer. Therefore, any deviation of the supply from the ideal supply can be referred to as degradation in the *supply quality*. The terms *loading quality* and *supply quality*, however, are not as commonly used, as the term *power quality*.

The concept of *quality* involves immediately an issue of its *measure*. Unfortunately, the loading, supply and the power qualities are affected by various agents and their effects usually defy any quantitative comparison. Consequently, the measures of the loading, supply or power qualities can be based only of conventions or standards. Moreover, it is much easier to talk about these qualities in terms of their *degradation* or *improvement*, regarded only as qualitative terms.

Nonetheless, even if the quality is described only in a qualitative way, in terms of the *loading quality* or the *supply quality*, problems with these qualities degradation are specified much more distinctively as compared to situation when they are described in terms of *power quality*.

For example, an increase in the voltage and current asymmetry in a cross-section between the supply and the load can be characterized as a degradation in the power quality. It is not very informative, however, because it can be an effect of two, distinctively different causes. It can occur because of asymmetry of the distribution voltage, meaning a degraded supply quality, or as a result of the load imbalance, meaning a degraded loading quality.

The discussion in this paper is confined to PWM inverter-based shunt switching compensators (SSC) in three-phase, three-wire systems, i.e., compensators connected as shown in Fig. 1. Line inductors are regarded as a part of the compensator and are not drawn in Fig. 1.

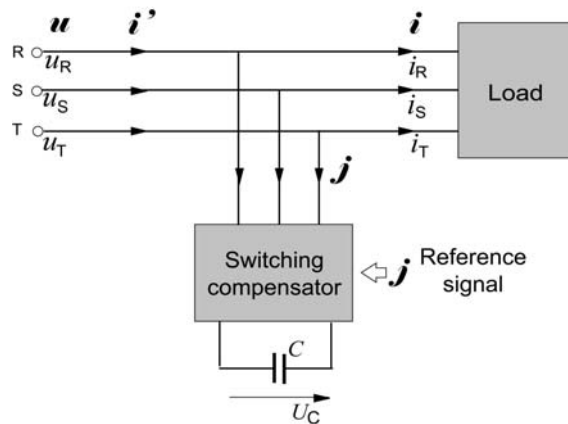

**Figure 1.** Three-phase, three-wire load with shunt switching compensator (SSC)

Because this is irrelevant from the point of view of the reference signal generation, it is assumed that the compensator ideally reproduces the reference signal as its input current  $\mathbf{j}$ . Therefore, the same symbol is used for this current and the reference signal, although the reference signal is only a digital signal, generated by a Digital System Processing (DSP) system.

The compensator can operate in an open or closed control loop. When SSC operates in an open control loop, it should reproduce the reference signals as its input current. When it operates in a closed control

loop, it should compensate deviations from the desirable current. The basic operation of a compensator is its operation in an open loop however, meaning the compensator reproduces the reference signal as the compensator current as accurately as possible. Generation of this reference signal,  $\mathbf{j}$ , based on data from the load voltages and currents is a crucial issue for the compensator control.

Most of algorithms for reference signal generation stem from the Instantaneous Reactive Power (IRP) p-q theory [2]. The Synchronous Reference Frame (SRF) algorithm [3, 8] is one of them. There are also algorithms that stem from the Fryze's power theory [1, 7]. The FDB method [4] is one such algorithm. Unfortunately, it was shown in Ref. [7, 9] that both IRP p-q theory and Fryze's power theory misinterpret power related phenomena in electrical systems. These misinterpretations may affect the reference signals.

This paper shows how the Currents' Physical Components based power theory can be implemented for generating the reference signal for the SSC control.

### III. COMPENSATION OBJECTIVES

The primary objective of compensation, specified in this paper as *objective G0*, is minimization of the cost of energy delivery to the load and utilization of this energy. The extra cost of energy delivery and utilization, caused by the reduced quality of the load and/or the supply, has a number of components. Some of them, for example, the cost of extra loss of energy, can be evaluated relatively easily. However, it can be very difficult to predict the cost of accelerated aging of equipment, cost of disturbances and the reduced reliability. Compensation involves some cost as well. It is the investment cost of the compensator, but also the cost of energy needed to run the compensator.

Therefore, due to the lack of data, minimization of the cost of energy delivery and utilization, that includes also the cost of the compensation is very difficult to achieve. Such minimization, meaning objective *G0*, can be regarded rather as an ideal objective of compensation and has to be superseded by objectives that can be practically achieved.

Objectives of compensation, other than *G0*, often based on an engineering intuition and adjusted to specific situations, can have a variety of forms. Objective *G0* confined to the supply will be referred to as *objective GSO*, while applied to customer loads will be referred to as *objective GLO*. Objective *GSO*, meaning minimization of the extra cost of energy delivery which increases with degradation of the loading quality, requires shunt compensation or filtering. Objective *GLO*, meaning minimization of the cost of energy utilization in the load which increases with degradation in the supply quality, requires series filtering or compensation. Unfortunately, objectives *GSO* and *GLO*, for similar reasons as objective *G0*, are rather ideal than practical objectives. Minimization of the supply current rms value with a shunt compensator or filter is such a practical objective, which reduces the cost of energy delivery. It will be referred to as *objective GSc*.

### IV. MINIMIZATION OF FRYZE REACTIVE CURRENT

There are two different approaches to the objective *GSc*. One of them is founded on the Fryze power theory. It was formulated originally for single-phase loads with nonsinusoidal supply voltage in Ref. [1]. It can be generalized [12] to three-phase loads as follows. Line currents  $i_R, i_S, i_T$  and supply voltages  $u_R, u_S$  and  $u_T$ , measured with respect to an artificial zero, can be arranged into vectors

$$\mathbf{i} \triangleq \mathbf{i}(t) \triangleq \begin{bmatrix} i_R \\ i_S \\ i_T \end{bmatrix}, \quad \mathbf{u} \triangleq \mathbf{u}(t) \triangleq \begin{bmatrix} u_R \\ u_S \\ u_T \end{bmatrix} \quad (1)$$

The load active power  $P$  can be expressed as the scalar product of the load voltage and current vectors

$$P \triangleq (\mathbf{u}, \mathbf{i}) \triangleq \frac{1}{T} \int_0^T \mathbf{u}^T(t) \mathbf{i}(t) dt, \quad (2)$$

while the rms value of a three phase vector  $\mathbf{x}$  is

$$\|\mathbf{x}\| \triangleq \sqrt{(\mathbf{x}, \mathbf{x})} = \sqrt{\frac{1}{T} \int_0^T \mathbf{x}^2(t) dt} = \sqrt{\|x_R\|^2 + \|x_S\|^2 + \|x_T\|^2}. \quad (3)$$

The load current vector,  $\mathbf{i}(t)$ , can be decomposed into the active and the reactive currents

$$\mathbf{i} = \mathbf{i}_a + \mathbf{i}_{rF}. \quad (4)$$

The active current vector is defined as

$$\mathbf{i}_a \triangleq \frac{P}{\|\mathbf{u}\|^2} \mathbf{u} = G_e \mathbf{u}, \quad (5)$$

while the reactive current, according to Fryze's definition is

$$\mathbf{i}_{rF} \triangleq \mathbf{i} - \mathbf{i}_a, \quad (6)$$

The active current,  $\mathbf{i}_a$ , is the current of an ideal load that at voltage  $\mathbf{u}$  has active power  $P$ . The reactive current,  $\mathbf{i}_{rF}$ , occurs as an effect of degraded loading quality. Compensation of this current will be denoted as *objective GScF* in this paper.

The objective *GScF* is simple, convincing and easy for implementation by switching compensators. Since the reactive current  $\mathbf{i}_{rF}$  is defined in the time-domain, there are even opinions that reference signals for compensator control can be generated instantaneously. This instantaneous control is, of course, only apparent because one period  $T$  is needed for measuring the active power  $P$  of the load and for measuring the voltage vector rms value  $\|\mathbf{u}\|$ .

Unfortunately, compensation according to objective *GScF* can lead to results difficult to accept. It is illustrated on an example of compensation of a single-phase load. In such a case, Fryze's decomposition of the load current has the form

$$i = i_a + i_{rF}, \quad (7)$$

and a compensator that fulfills the objective *GScF* should be connected as shown in Fig. 2.

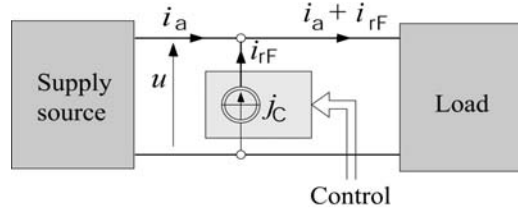

**Figure 2.** Circuit with a compensator that compensates the Fryze's reactive current

The load reactive current,  $i_{rF}$ , is detected in this circuit by a measurement and signal processing system and used next for controlling a current source, which reproduces this current and injects it into the supply lines. To show that this apparently obvious concept can lead to results difficult to accept, let us assume that a resistive load in the circuit shown in Fig. 3, supplied with a sinusoidal voltage

$$e = 100\sqrt{2} \sin \omega t \text{ V}, \quad (8)$$

generates a current harmonic of the third order

$$j = 50\sqrt{2} \sin 3\omega t \text{ A}. \quad (9)$$

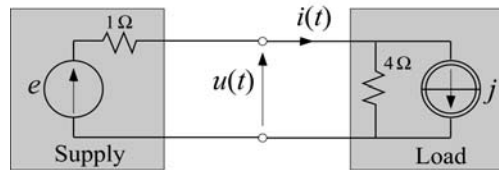

**Figure 3.** Circuit with harmonic generating load

The voltage and current at the load terminals in this circuit are equal to

$$u = 80\sqrt{2} \sin \omega t - 40\sqrt{2} \sin 3\omega t \text{ V}, \quad (10)$$

$$i = 20\sqrt{2} \sin \omega t + 40\sqrt{2} \sin 3\omega t \text{ A}. \quad (11)$$

Thus, the load active power is

$$P = \frac{1}{T} \int_0^T u i dt = 80 \times 20 - 40 \times 40 = 1600 - 1600 = 0, \quad (12)$$

and the active current is equal to zero, since

$$i_a = \frac{P}{\|u\|^2} u \equiv 0. \quad (13)$$

It means that according to the Fryze power theory, there is no current in this circuit other the reactive current:

$$i_{\text{TF}} = i = 20\sqrt{2} \sin \omega_1 t + 40\sqrt{2} \sin 3\omega_1 t = i_1 + i_3, \quad (14)$$

and a compensator that fulfills the objective *GScF* should compensate it entirely. This would be, of course, a wrong conclusion. Such compensation would stop the energy flow from the source to the load entirely. Instead of compensating the Fryze's reactive current,  $i_{\text{TF}}$ , the third order current harmonic  $j$  generated in the load should be compensated. Meaning, the compensated load behaves as an ideal load when the compensator injects the current

$$j = 100\sqrt{2} \sin 3\omega_1 t \text{ A}, \quad (15)$$

into the load supply lines, but not the reactive current  $i_{\text{TF}}$ .

When a compensator achieves the objective *GScF*, the supply  $\mathbf{i}^*$  current is proportional to the supply voltage,

$$\mathbf{i}^* = \mathbf{i}_a = G_c \mathbf{u}, \quad (16)$$

thus, if the distribution voltage is distorted and asymmetrical, then the supply current after compensation has to be distorted and asymmetrical as well. Thus, the objective *GScF* can be questionable. One might rather expect that this current after compensation should be sinusoidal and symmetrical. Compensation to such a current will be denoted as *objective GScI*.

## V. COMPENSATION TO SINUSOIDAL SYMMETRICAL CURRENT

The vector of the supply voltages  $u_R$ ,  $u_S$  and  $u_T$ , of a three-wire system, in general asymmetrical and nonsinusoidal, can be decomposed into vectors of the positive and negative sequence components of the fundamental harmonic  $\mathbf{u}_1^p$ ,  $\mathbf{u}_1^n$ , and a harmonic component  $\mathbf{u}_h$ , as follows.

$$\mathbf{u} = \mathbf{u}_1 + \sum_{n \in N} \mathbf{u}_n = \mathbf{u}_1^p + \mathbf{u}_1^n + \mathbf{u}_h. \quad (17)$$

The active power  $P$  of a load supplied with such a voltage is composed of active powers of the fundamental  $P_1$  and all higher order harmonics,  $P_n$ , i.e.,

$$P = P_1 + \sum_{n \in N} P_n \triangleq P_1 + P_h, \quad (18)$$

where  $N$  denotes the set of orders,  $n$ , of the voltage harmonics, without the fundamental. The active power of harmonics other than the fundamental contributes, for sure, to a useful power only in resistive loads. The active power of harmonics in machines and electronic devices contributes rather to extra heating or vibrations and should not be considered as useful power.

The active power of the fundamental harmonic with asymmetrical supply voltages in three-wire systems is composed of active power of the positive and negative sequences, i.e.,

$$P_1 = P_1^p + P_1^n. \quad (19)$$

Most of the electrical energy in electrical power systems is converted to mechanical energy by rotating machines. For example, such machines use 2/3 of the energy produced in the US power system. This portion can be even higher when we are confined to industrial systems. Therefore, we can assume that approximately only the active power of the positive sequence component of the fundamental harmonic represents the useful active power, while other components of this power contribute rather to a harmful power.

The active power of a resistive balanced load of the phase conductance  $G_{e1}^p$  supplied with a positive sequence voltage  $\mathbf{u}_1^p$  is

$$P_1^p \triangleq (\mathbf{u}_1^p, \mathbf{i}_1^p) = G_{e1}^p \|\mathbf{u}_1^p\|^2 = \|\mathbf{i}_{1a}^p\| \|\mathbf{u}_1^p\|, \quad (20)$$

where

$$\mathbf{i}_{1a}^p = G_{e1}^p \mathbf{u}_1^p = \frac{P_1^p}{\|\mathbf{u}_1^p\|^2} \mathbf{u}_1^p. \quad (21)$$

It is the smallest supply current needed for providing power  $P_1^p$  at the supply voltage  $\mathbf{u}_1^p$ . Let us suppose that this voltage is only a positive sequence component of the fundamental harmonic of the supply voltage  $\mathbf{u}$  and the load is not balanced and purely resistive, but such that at the voltage  $\mathbf{u}_1^p$  it has the active power  $P_1^p$ . The current  $\mathbf{i}_{1a}^p$  is only a component of the supply current  $\mathbf{i}$  of such a load. The remaining part of the supply current

$$\mathbf{i}_d = \mathbf{i} - \mathbf{i}_{1a}^p, \quad (22)$$

referred to as a *detrimental current* in this paper, contains the negative sequence component of the active current, as well as the reactive, unbalanced, scattered currents and load generated harmonic currents.

Consequently, the scalar product  $(\mathbf{u}_1^p, \mathbf{i}_d) = 0$ , and

$$(\mathbf{u}, \mathbf{i}_d) = (\mathbf{u}_1^p + \mathbf{u}_1^n + \mathbf{u}_h, \mathbf{i}_d) = (\mathbf{u}_1^p, \mathbf{i}_d) + (\mathbf{u}_1^n, \mathbf{i}_d) + (\mathbf{u}_h, \mathbf{i}_d) = P_1^n + P_h. \quad (23)$$

Terms such as “the current, voltage or the active power, equivalent conductance for the positive sequence component of the fundamental harmonic” are too complex to be used in a common language, similarly, as too complex are their symbols in writing. Therefore, these quantities will be referred to as the *working current*, *working voltage*, *working power* and the *working conductance of the load* and denoted as

$$\mathbf{i}_w \triangleq \mathbf{i}_{1a}^p, \quad \mathbf{u}_w \triangleq \mathbf{u}_1^p, \quad P_w \triangleq P_1^p, \quad G_w \triangleq G_{e1}^p, \quad (24)$$

respectively. It will enable simple referring to these quantities or parameters without a long description of their features.

Reduction of the supply current  $\mathbf{i}$  to the working current  $\mathbf{i}_w$  means the fulfillment of the objective *GScI*. To do so, the compensator should generate and inject the detrimental current  $\mathbf{i}_d$  into the load supply lines, meaning that the reference signals and consequently, the compensator current should be calculated according to the formula:

$$\mathbf{j} = \mathbf{i}_d = \mathbf{i} - \mathbf{i}_w = \mathbf{i} - \frac{P_w}{\|\mathbf{u}_w\|^2} \mathbf{u}_w. \quad (25)$$

Assuming that compensator does not affect the supply voltage, observe however, that the compensator also does not affect the load active power,  $P$ , while reduction of the supply current,  $\mathbf{i}$ , to its working component,  $\mathbf{i}_w$ , reduces the active power at the supply terminals to the working power,  $P_w$ . This would violate the balance principle. It means the supply current after compensation has to contain, as shown in Fig. 4, some complementary current,  $\mathbf{i}_c$ .

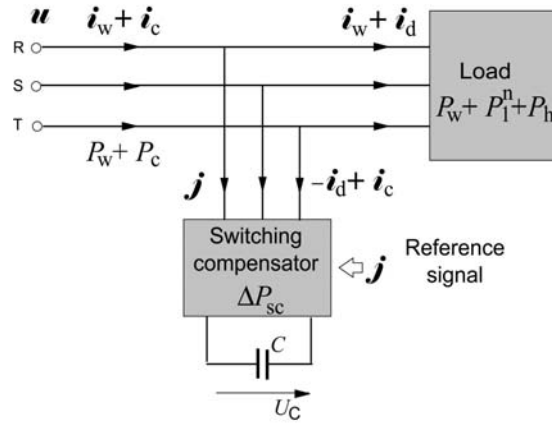

**Figure 4.** Modification of currents and active powers in a system with SSC

This current, generated by the compensator, should be sinusoidal and symmetrical and of such a value that the balance principle of the active power is preserved.

Due to energy loss in the compensator and its input filter, some amount of energy has to be delivered to the compensator. It is not stored on the condition that the capacitor voltage,  $U_C$ , remains constant, meaning on the condition that

$$(\mathbf{u}, \mathbf{j}) - \Delta P_{sc} = 0, \quad (26)$$

where  $\Delta P_{sc}$  denotes the active power loss in the compensator and the filter. Since the compensator current is equal to

$$\mathbf{j} = -\mathbf{i}_d + \mathbf{i}_c, \quad (27)$$

hence

$$-(\mathbf{u}, \mathbf{i}_d) + (\mathbf{u}, \mathbf{i}_c) - \Delta P_{sc} = 0. \quad (28)$$

Thus, the complementary active power,  $P_c$ , at the supply terminals is equal to

$$P_c = (\mathbf{u}, \mathbf{i}_c) = \Delta P_{sc} + (\mathbf{u}, \mathbf{i}_d) = \Delta P_{sc} + P_1^n + P_h, \quad (29)$$

and with such a power the power balance principle is satisfied. complementary current,  $\mathbf{i}_c$ , is in-phase with the working voltage,  $\mathbf{u}_w$ , and it is equal to

$$\mathbf{i}_c = \frac{P_c}{\|\mathbf{u}_w\|^2} \mathbf{u}_w = \frac{\Delta P_{sc} + P_1^n + P_h}{\|\mathbf{u}_w\|^2} \mathbf{u}_w. \quad (30)$$

This formula cannot be used, however, for the complementary current control. Although the value  $P_1^n + P_h = P - P_w$  can be measured, the power loss  $\Delta P_{sc}$  is unknown. Instead, such a current is generated by the compensator, when the capacitor voltage,  $U_C$ , is kept constant by this voltage control system, which affect the in-phase component,  $\mathbf{i}_c$ , of the compensator current, meaning the eqn. (26) is satisfied, which consequently leads to eqn. (30). One should observe, however, that the change of the supply current by the compensator affects the load voltage and consequently, the power equation (29) is only approximate.

## VI. PROGRAMABLE COMPENSATION OBJECTIVE

The compensation with objective *GScI* and the reference signals for the compensator control, generated according to formula (25), provides a sort of global compensation, meaning the detrimental current,  $\mathbf{i}_d$ , is compensated as a whole. It is a simple, straightforward approach.

Although beneficial in some situations, such an approach can be unfavorable when the cost of the compensator or its power rating is a matter of concern.

The power rating of the PWM inverter, which is the very core of switching compensators, is limited by the switching capability of power transistors and this power declines with the switching frequency. High switching frequency is only needed however, for compensation of high frequency components of

the detrimental current, meaning high order harmonics. This frequency can be substantially lower for compensation of the fundamental frequency components, such as the negative sequence component of the active current and the reactive or unbalanced currents of the fundamental. Even more, the reactive or unbalanced currents do not have to be compensated with a PWM-based switching compensator at all. A conventional adaptive reactive compensator with *Thyristor Controlled Susceptances* (TCS) can compensate [5, 6] these two components of the detrimental current, without limitations imposed upon the compensator power rating by the transistors' switching power. Consequently, a *hybrid compensator*, composed of a PWM-based switching compensator, and a *balancing reactive compensator* can substantially expand the range of power of compensable loads.

Therefore, it can be advantageous if the major components of the detrimental current  $\mathbf{i}_d$  are managed individually and compensated according to a hierarchy of their importance and the compensator power. Compensation that enables individual management of the major components of the detrimental current will be referred as *programmable compensation* in this paper. Such a programmable compensation will be referred to as *objective GScIP*.

## VII. REFERENCE SIGNALS FOR COMPENSATION OBJECTIVE GScI

The vector  $\mathbf{i}_w$  of the working current, meaning the current which, apart the complementary current,  $\mathbf{i}_c$ , has to remain in the supply lines in the effect of compensation with objective *GScI* can be expressed as follows

$$\mathbf{i}_w \triangleq \frac{P_1^p}{\|\mathbf{u}_1^p\|^2} \mathbf{u}_1^p = \frac{3U_1^p I_1^p \cos\varphi_1^p}{(\sqrt{3}U_1^p)^2} \mathbf{u}_1^p = I_1^p \cos\varphi_1^p \frac{1}{U_1^p} \mathbf{u}_1^p. \quad (31)$$

Since the rms value of the working current is

$$I_w \triangleq I_1^p \cos\varphi_1^p, \quad (32)$$

thus

$$\mathbf{i}_w = I_w \frac{1}{U_1^p} \mathbf{u}_1^p = \sqrt{2} I_w \begin{bmatrix} \cos(\omega_1 t + \alpha_1^p) \\ \cos(\omega_1 t + \alpha_1^p - 120^\circ) \\ \cos(\omega_1 t + \alpha_1^p + 120^\circ) \end{bmatrix}, \quad (33)$$

where  $\alpha_1^p$  is the argument of the complex rms (crms) value  $U_1^p$  of the positive sequence component of the voltage fundamental harmonic, equal to  $U_1^p \triangleq U_1^p e^{j\alpha_1^p}$ .

This means, that only the rms value of the positive sequence components of the load current fundamental harmonic  $I_1^p$  and the phase shift  $\varphi_1^p$  between this component and positive sequence components of the supply voltage fundamental harmonic are needed for calculating the vector  $\mathbf{i}_w$  of the working current and consequently, the reference signals for the switching compensator control. Thus, the following crms values have to be calculated

$$U_1^p \triangleq U_1^p e^{j\alpha_1^p}, \quad I_1^p \triangleq I_1^p e^{j\beta_1^p}, \quad \varphi_1^p \triangleq \alpha_1^p - \beta_1^p, \quad (35)$$

meaning, calculating the reference signals involves the Fourier decomposition.

The necessity of using computationally intensive Fourier decomposition is usually the major argument against using the frequency-domain approach for the SSC control. In fact, such an approach does not have to be computationally demanding. It is because the Fourier decomposition needed for the control can be confined only to calculating the crms value of the fundamental harmonic.

Let  $x(t)$  denote a line current or voltage and  $x_k$  denote its  $N$  samples taken in equidistant sampling intervals  $T_s$  in the period  $T$ . The crms value of the fundamental harmonic  $X_1$  of quantity  $x(t)$ , calculated with the Discrete Fourier Transform (DFT) is

$$X_1 \triangleq X_1 e^{j\alpha_1} = \frac{\sqrt{2}}{N} \sum_{k=0}^{N-1} x_k e^{-j\frac{2\pi}{N}k}. \quad (36)$$

Calculation of this value for a single quantity requires, indeed,  $2N$  multiplications of real numbers. This crms value can be calculated, however, in a recursive way [6]. Namely, when its value  $\mathbf{X}_{1k-1}$  at instant  $t_{k-1}$  is known, then this value at instant  $t_k$  is

$$\mathbf{X}_{1k} = \mathbf{X}_{1k-1} + (x_k - x_{k-N})\mathbf{W}^k, \quad \mathbf{W}^k \triangleq \frac{\sqrt{2}}{N} e^{-j\frac{2\pi}{N}k}. \quad (37)$$

When  $N$  complex values of

$$\mathbf{W}^k = \frac{\sqrt{2}}{N} e^{-j\frac{2\pi}{N}k} = \frac{\sqrt{2}}{N} \cos\left(\frac{2\pi}{N}k\right) - j \frac{\sqrt{2}}{N} \sin\left(\frac{2\pi}{N}k\right), \quad (38)$$

are stored in a computer memory, then only two multiplications are needed to update the crms value  $\mathbf{X}_{1k-1}$  to  $\mathbf{X}_{1k}$ . This updating is needed, moreover, only when the periodicity of quantity  $x(t)$  is disturbed, meaning the sample  $x_k$  is not equal to the sample taken one period  $T$  earlier,  $x_{k-N}$ . One should observe, however, that recursive calculations are prone to the accumulation of errors caused by the rounding of products and sums. Therefore, it is necessary that rounding algorithms provide random errors with a zero mean value. Moreover, cyclical updating of the  $\mathbf{X}_{1k-1}$  value calculated directly with the DFT formula (36) can be taken into account. This cyclical updating has to be performed, of course, in parallel with the main process of the reference signal generation.

Thus, calculation of the crms values of the fundamental harmonic  $\mathbf{I}_{R1}$ ,  $\mathbf{I}_{S1}$ ,  $\mathbf{U}_{RT1}$  and  $\mathbf{U}_{ST1}$  of line currents  $i_R$ ,  $i_S$  and line-to-line voltages,  $u_{RT}$  and  $u_{ST}$  with the recursive formula requires no more than eight multiplications of real numbers.

Symmetrical components of the line current's fundamental harmonic in three line systems are equal to

$$\begin{bmatrix} \mathbf{I}_1^p \\ \mathbf{I}_1^n \end{bmatrix} = \frac{1}{3} \begin{bmatrix} 1, \alpha, \alpha^* \\ 1, \alpha^*, \alpha \end{bmatrix} \begin{bmatrix} \mathbf{I}_{R1} \\ \mathbf{I}_{S1} \\ \mathbf{I}_{T1} \end{bmatrix} = \frac{1}{\sqrt{3}} \begin{bmatrix} e^{j30^\circ}, & e^{j90^\circ} \\ e^{-j30^\circ}, & e^{-j90^\circ} \end{bmatrix} \begin{bmatrix} \mathbf{I}_{R1} \\ \mathbf{I}_{S1} \end{bmatrix}. \quad (39)$$

The crms value of the positive sequence current  $\mathbf{I}_1^p$ , is equal to

$$\mathbf{I}_1^p = \frac{1}{\sqrt{3}} (\mathbf{I}_{R1} e^{j30^\circ} + \mathbf{I}_{S1} e^{j90^\circ}), \quad (40)$$

and only one multiplication is needed to calculate it, because multiplication by the complex number  $e^{j\alpha}$  means only argument summation.

The supply voltage positive sequence harmonic,  $\mathbf{U}_1^p$ , has to be calculated using crms values of the line-to-line voltages  $\mathbf{U}_{RT1}$  and  $\mathbf{U}_{ST1}$ . It is equal to

$$\mathbf{U}_1^p = \frac{1}{3} (\mathbf{U}_{R1} + \alpha \mathbf{U}_{S1} + \alpha^* \mathbf{U}_{T1}) = \frac{1}{3} (\mathbf{U}_{RT1} + \mathbf{U}_{ST1} e^{j120^\circ}). \quad (41)$$

Since only the phase angle  $\alpha_1^p$  of the crms value  $\mathbf{U}_1^p$  is needed for the reference signal calculation, it can be obtained from eqn. (41) without any multiplication. It means that calculation of the working current rms value  $I_w$  requires only nine multiplications. Assuming that the values of  $\sqrt{2} \cos \alpha$  are stored in a look-up table, two additional multiplications are needed for calculating the reference signals for phases R and S. No multiplication is needed for calculating the reference signal for the phase T, since  $i_{Tw} = -(i_{Rw} + i_{Sw})$ . The accurate number of multiplications depends, of course, on details of the control code, which can be written in various ways, nonetheless, we can conclude that generation of the reference signal for compensation according to objective *GScI* is not computationally very demanding.

## VIII. REFERENCE SIGNALS EXTRAPOLATION

The sequential values of the reference signals  $\mathbf{j}_k$  can be calculated after the latest set of voltages and currents  $\mathbf{u}_k$  and  $\mathbf{i}_k$  samples at the instant  $t_k$  are provided, meaning that the value of the calculated control signal is

$$\mathbf{j}_k = \mathbf{i}_k - G_{w,k} \mathbf{u}_{w,k}. \quad (42)$$

Before this sequential value is calculated and reproduced as compensating currents  $\mathbf{j}_k$ , the load current changes, however, to a new and unknown value  $\mathbf{i}_{k+1}$ . Thus, a lag of the compensating current cannot be avoided. If the sampling frequency is selected such that the sampling interval  $T_s$  is fitted to the time interval needed for all calculations, it can be assumed that the delay of the compensator current is equal to the sampling interval. This means that the compensating current needed at the instant  $t_k$  is injected at the instant  $t_{k+1}$ . Thus, a compensation error has to occur.

The compensation error caused by this delay can be reduced by the prediction of the reference signal value at the instant  $t_{k+1}$ . Such prediction can be based on a simple linear extrapolation, meaning on the assumption that unknown changes of concern in the interval  $(t_k, t_{k+1})$  are equal to the known respective changes in the interval  $(t_{k-1}, t_k)$ . Thus

$$\mathbf{j}_{k+1} = \mathbf{i}_{k+1} - G_{w,k+1} \mathbf{u}_{w,k+1}, \quad (43)$$

with

$$\mathbf{i}_{k+1} = \mathbf{i}_k + (\mathbf{i}_k - \mathbf{i}_{k-1}) = 2\mathbf{i}_k - \mathbf{i}_{k-1}, \quad (44)$$

$$G_{w,k+1} = G_{w,k} + (G_{w,k} - G_{w,k-1}) = 2G_{w,k} - G_{w,k-1}, \quad (45)$$

$$\mathbf{u}_{w,k+1} = \mathbf{u}_{w,k} + (\mathbf{u}_{w,k} - \mathbf{u}_{w,k-1}) = 2\mathbf{u}_{w,k} - \mathbf{u}_{w,k-1}. \quad (46)$$

Observe that this approach enables generation of the reference signal almost instantaneously, based on two measurements separated only by the sampling interval  $T_s$  and, at the same time, the ‘‘history’’ of the load in the last period  $T$  is taken into account. Therefore, such generation of the reference signal will be referred to as *quasi-instantaneous*. The current vector values  $\mathbf{i}_k$  stand for the instantaneous component of the signal, while the working conductance  $G_{w,k}$  and working voltage  $\mathbf{u}_{w,k}$  are obtained in a process of averaging of  $N$  measurements over the period  $T$ . The conductance  $G_w$ , rms value and phase of the voltage vector  $\mathbf{u}_w$  entries, as a result of this averaging, are constant or slowly varying parameters.

## IX. REFERENCE SIGNALS FOR PROGRAMMABLE COMPENSATION OBJECTIVE *GSCIP*

The detrimental current  $\mathbf{i}_d$ , meaning the residual component of the load current after subtraction of the working current, contains the fundamental and harmonic components

$$\mathbf{i}_d \triangleq \mathbf{i} - \mathbf{i}_w = \mathbf{i}_{d1} + \mathbf{i}_h. \quad (47)$$

After the crms values of the fundamental harmonic  $I_{R1}$ ,  $I_{S1}$ ,  $U_{RT1}$  and  $U_{ST1}$  are calculated as shown in Section VII, these two components can be separated easily. Namely

$$\mathbf{i}_{d1} \triangleq \mathbf{i}_1 - \mathbf{i}_w = \sqrt{2} \text{Re}\{(I_1 - I_w) e^{j\omega t}\}, \quad (48)$$

where

$$I_1 \triangleq \begin{bmatrix} I_{R1} \\ I_{S1} \\ I_{T1} \end{bmatrix}, \quad I_w \triangleq \begin{bmatrix} I_{R1w} \\ I_{S1w} \\ I_{T1w} \end{bmatrix} = \begin{bmatrix} 1 \\ \alpha^* \\ \alpha \end{bmatrix} I_1^p, \quad (49)$$

while

$$\mathbf{i}_h \triangleq \mathbf{i} - \mathbf{i}_1 = \mathbf{i} - \sqrt{2} \text{Re}\{I_1 e^{j\omega t}\}. \quad (50)$$

Components  $\mathbf{i}_{d1}$  and  $\mathbf{i}_h$  of the detrimental current  $\mathbf{i}_d$  can be used in two different ways. First, the vector of the reference signal can be created as a linear form

$$\mathbf{j} = C_1 \mathbf{i}_{d1} + C_h \mathbf{i}_h, \quad (51)$$

where coefficients  $C_1$  and  $C_2$  are selected at the discretion of the compensator’s designer. Thus, the designer can make the decision as to which degree each of these two components should be compensated. If  $\mathbf{i}_{d1}$  represents the reactive current vector, then selection of the coefficient  $C_1$  above or below unity enables over- or under-compensation of the reactive power.

Observe, moreover, that compensation of the harmonic component  $\mathbf{i}_h$  requires a much higher switching frequency of the PWM inverter than compensation of the fundamental component  $\mathbf{i}_{d1}$  of the detrimental current. At the same time, reduction of the switching frequency enables an increase in the power rating of the compensator. There are situations where the reactive and/or the unbalanced currents

are the major components of the load currents. A hybrid compensator composed of two separate compensators, one with lower switching frequency, but higher power and the second, with higher switching frequency, but lower power could be advantageous in such a situation with respect to the available power ratings and cost over a conventional compensator. Vectors  $\mathbf{i}_{d1}$  and  $\mathbf{i}_h$  provide reference signals for such a hybrid compensator control, meaning that their reference signals can have the form

$$\mathbf{j}_{d1} = C_1 \mathbf{i}_{d1}, \quad \mathbf{j}_h = C_h \mathbf{i}_h. \quad (52)$$

The programmable compensation objective *GScIP* can be achieved, moreover, in a wider class of compensators than only PWM-based switching compensators. Such a compensator is not needed for compensating the reactive  $\mathbf{i}_{r1}$  and unbalanced  $\mathbf{i}_{u1}$  components of the fundamental harmonic  $\mathbf{i}_1$ . These two components, often dominating in the rms value of the load current, can be compensated by a reactive compensator with, if needed, an adaptive property. Such a compensator of the reactive and unbalanced power can be built [5, 6] with thyristors, instead of transistor switches. It considerably elevates the limits for the compensator power rating, confined in the case of PWM-based compensators by the switching capability of power transistors.

## X. CONCLUSIONS

Compensation goals as presented in papers on compensation are usually rather vague. Moreover, it is often not easy to compare these goals when they are expressed in different ways, according to the concept of the IRP p-q, Fryze, d-q, FDB, or CPC-based power theory, used for generating the reference signals for the compensator control.

Compensation can indeed stand for different things, and therefore, a draft classification of various goals of shunt compensation was presented in the paper. The Currents' Physical Component power theory was used for this classification and consequently, this classification was presented only in the CPC terms. It would be interesting to see such classifications in terms of other approaches to power theory.

Apart from the classification of shunt compensation objectives, it was demonstrated in the paper that the CPC power theory is a universal tool for quasi-instantaneous generation of the reference signals for switching compensator control for a variety of compensation objectives.

## REFERENCES

- [1] S. Fryze, "Active, reactive and apparent powers in systems with distorted waveform," (in Polish), *Przegląd Elektrotechniczny*, Z. 7, 193-203, 1931; Z. 8, 225-234, 1932.
- [2] H. Akagi, Y. Kanazawa and A. Nabae, "Instantaneous reactive power compensators comprising switching devices without energy storage components," *IEEE Trans. on IA*, IA-20, 1984, No. 3, pp. 625-630.
- [3] S. Bhattacharya, D.M. Divan, B. Banerjee, "Synchronous frame harmonic isolator using active series filter," *Int. Conf. on Power Electronics, EPE*, Firenze, 1991, pp. 30-35
- [4] M. Depenbrock, H.-Ch. Skudelny, "Dynamic compensation of non-active power using the FDB method – basic properties demonstrated by benchmark examples," *Europ. Trans. on Electrical Power Syst. ETEP*, Vol. 4, No. 5, pp. 381-388, Sept./Oct. 1994.
- [5] L.S. Czarnecki, S.M. Hsu, G. Chen, "Adaptive balancing compensator," *IEEE Trans. on Power Del.*, Vol. 10, No. 3, pp. 1663-1669, July 1995.
- [6] L.S. Czarnecki, "Application of running quantities for a control of an adaptive hybrid compensator," *Europ. Trans. on Electrical Power Syst. ETEP*, Vol. 6, No.5, 337-344, Sept./Oct. 1996.
- [7] L.S. Czarnecki, "Budeanu and Fryze: two frameworks for interpreting power properties of circuits with nonsinusoidal voltages and currents," *Archiv für Elektrotechnik*, (81), N. 2, pp. 5-15, 1997.
- [8] L.E. de Oliveira et al. "Improving the dynamic response of active power filters based on the synchronous reference frame method," *IEEE publ.* 0-7803-7404-5/02/2002, pp. 742-748.
- [9] L.S. Czarnecki, "On some misinterpretations of the Instantaneous Reactive Power p-q Theory," *IEEE Trans. on Power Electronics*, Vol. 19, No. 3, 2004, pp. 828-836.
- [10] H.L. Ginn III, "A hybrid reference signal generator for active compensators," *7<sup>th</sup> Int. Workshop on Power Definitions and Measurement under Non-Sinusoidal Conditions*, Cagliari, Italy, 2006.
- [11] A. Firlit, "Current's physical components theory and p-q power theory in the control of the three-phase shunt active power filter," *7<sup>th</sup> Int. Workshop on Power Definitions and Measurement under Non-Sinusoidal Conditions*, Cagliari, Italy, 2006.
- [12] L.S. Czarnecki, "Currents' Physical Components (CPC) in circuits with nonsinusoidal voltages and currents. Part 2: Three-phase linear circuits," *Electrical Power Quality and Utilization Journal*, Vol. X, No.1, pp.1-14, 2006.